

Rugged 3U VPX Intel® Xeon® W-11865MRE Processor Blade

VPX3-TL Series

Datasheet

New

SOSA
Sensor Open Systems Architecture

VPX™ **VPX^{REDI}**™ **OpenVPX**™

**CONDUCTION
COOLED**

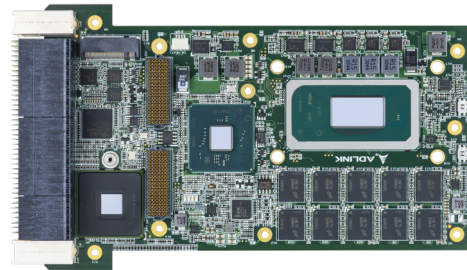

Features

- Intel® Xeon® W-11865MRE processor (formerly Tiger Lake-H); up to 8 cores with 45 watt TDP
- SOSA-aligned and VITA 46/47/48/65 compliant for quick deployment
- 32GB DDR4-2666 soldered ECC SDRAM (roadmap to 64GB)
- 1x M.2 2242 slot, supports NVMe and SATA SSD (upgradeable to 1TB by option)
- One XMC expansion slot with PCIe x8 Gen3 (according to product SKU)
- Ethernet connectivity: 1x 2.5GBASE-T to P2; 2x 10GBASE-KR to P1; optional 2x 1GBASE-KX to P1
- 1x DisplayPort to P2, supports DP++ with resolution up to 8K/60Hz

Specifications

Processor & System	CPU	Intel® Xeon® W-11865MRE processor (formerly Tiger Lake-H) Up to 8 cores (TDP 45W)
	Chipset	Intel® RM590E Chipset
	Memory	32GB DDR4 soldered with ECC (roadmap to 64GB)
	BIOS	Dual 256Mbit SPI flash
	VITA Standards	VITA 46/48/65 compliant SOSA aligned
	Module Profile	MOD3-PAY-1F1F2U1TU1T1U1T-16.2.15-2
	Slot Profile	SLT3-PAY-1F1F2U1TU1T1U1T- 14.2.16
Connectivity	XMC	1x PCIe x8 Gen3 to J15 Rear I/O (X16s+X8d) to P2 and X12d to P1 from J16 Supports +5V or +12V PWR by BOM option (default is +5V) Supports XMC 1.0 & 2.0 connector according to product SKU
	Dataplane	1x PCIe Gen3.0 x4 to P1 (Lane 0-3)
	Expansion Plane	1x PCIe Gen3.0 x4 to P1 (Lane 4-7)
	Control Plane	2x 10GBASE-KR to P1 (default) 2x 1GBASE-KX to P1 (BOM option) Supports IOL/SOL

Specifications

	User Defined	1x PCIe Gen3.0 x8 to P1 Lane 0-7 by BIOS menu selection
	Ethernet	1x 2.5GBASE-T to P2 Supports PXE Supports Wake-On-LAN (WOL)
	Video	1x DisplayPort to P2 Supports DP++ Resolution up to 8K @60Hz Display mode selection via BIOS
	USB	2x USB 2.0 to P2 1x USB 3.2 Gen1 to P2 Supports USB 3.0 power to P1/G7 (supply 0.9A) with overcurrent protection Supports USB 2.0 power to P2/G9 (supply 0.5A) with overcurrent protection
	Serial Ports	COM2: RS-232/422/485 to P2 (RS-232 is 2-wire) Max. data rate for RS-232/422/485 is 115200bps RS-485 supports auto flow control RS-232/422/485 mode configuration via BIOS
	Maintenance Console Port	COM1: 2-wire TX/RX on P1 Supports TIA-232 & LVCOMS (3.3V), mode configuration via BIOS
	PCIe	2x PCIe Gen3.0 x4 co-layout with XMC x8d+X16s (on P2) PCIe NT function not supported
	GPIO	1x GPIO to P1, 3x GPIO to P2 Supports +3.3V (default) or +5V GPIO by BOM option GPI with edge trigger or level trigger interrupt
Storage	SATA	1x SATA 6Gb/s to P2
	M.2	1x M.2 2242 on top side (M-key) Supports interface: PCIe3.0 x4 and SATA3.0 Supports module height: S1, S2, D1, D2 (D2 is default)
Security	TPM	Discrete TPM 2.0 chip
	BIOS	Dual BIOS support
Operating System	OS	Windows 10 IoT Enterprise LTSC 21H2 Linux (Kernel >5.13, RHEL >8.3)
Miscellaneous	LEDs	Blade status LEDs on front and rear
	Reset Button	Reset Button on front panel Maskrest button reserved on RTM
Mechanical & Environmental	Form Factor	3U VPX, conduction-cooled construction, 1" pitch (VITA 48.1)
	Operating Temp.	-40°C to +85°C at wedge locks (VITA 47.0, ECC4-CC4)
	Storage Temp	-55°C to +105°C
	Vibration	Random: 12Grms, 5Hz to 2000Hz (VITA 47.0, ECC4-V3) Sinusoidal: 5g, 20Hz to 2000Hz
	Shock	40g, 11 ms (VITA 47.0, ECC4-OS2)
	Relative Humidity	95% non-condensing
	Altitude	60,000 ft. (operating)
Safety & EMI	Certifications	CE (EN555032 / EN55035); FCC Part 15B Class A

VPX3-TL Block Diagram

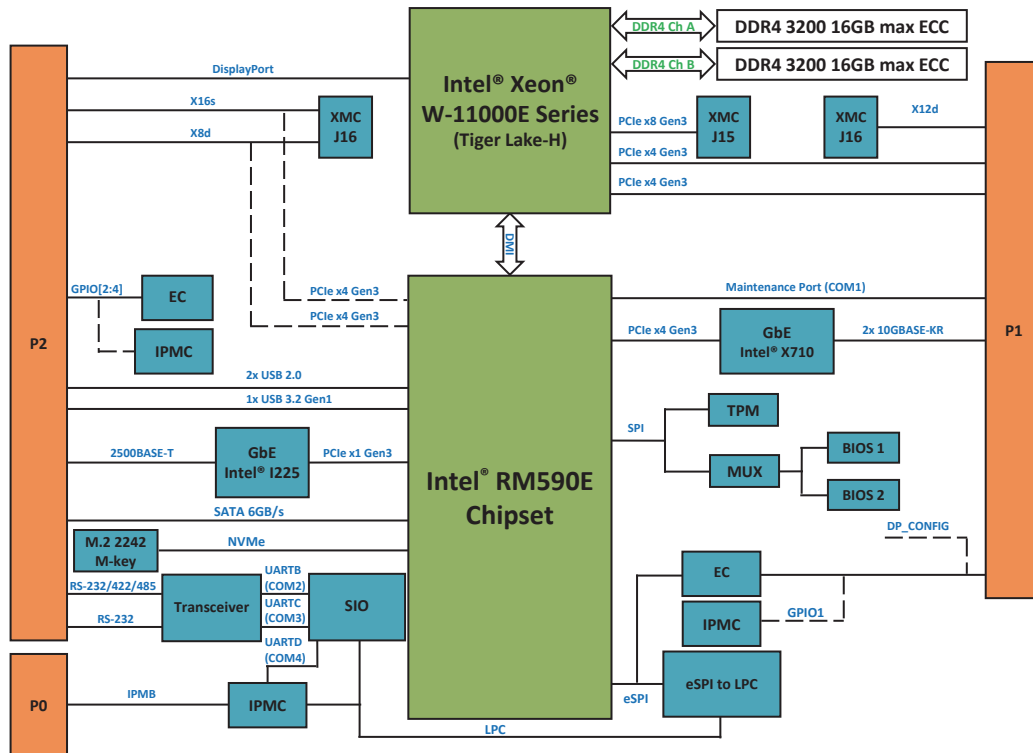

Ordering Information

Processor Blades

VPX3-TL/W-11865MRE/M32/ XMC1.0-R2, ETT, CC	3U VPX CPU blade with Intel® Xeon® W-11865MRE, DDR4 32GB, XMC 1.0 slot, conformal coating & ETT, -40°C to +85°C, conduction-cooled
VPX3-TL/W-11865MRE/M32/ XMC 2.0-R2, ETT, CC	3U VPX CPU blade with Intel® Xeon® W-11865MRE, DDR4 32GB, XMC 2.0 slot, conformal coating & ETT, -40°C to +85°C, conduction-cooled
VPX3-TL/W-11865MRE/M32/ P16-R2, ETT, CC	3U VPX CPU blade with Intel® Xeon® W-11865MRE, DDR4 32GB, without XMC slot, conformal coating & ETT, -40°C to +85°C, conduction-cooled

Backplane

tBP-VPX3-TL/XMC	Backplane for VPX3-TL with XMC
tBP-VPX3-TL/2xP4	Backplane for VPX3-TL with 2x PCIe x4